



Lakelands Concrete Products, Inc.
 7520 East Main St., Lima, NY 14485
 Phone: 585-624-1990, Fax: 585-624-2102

Web: www.lakelandsconcrete.com
 E-mail: sales@lakelandsconcrete.com

Date: 7/7/11

DWG: 6 Foot Dia

6'-0" Diameter Manhole

Syracuse Casting
 Frame & Cover

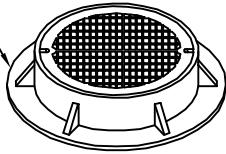

6" Grade Ring
 (If Required)
 Note: Height
 can vary

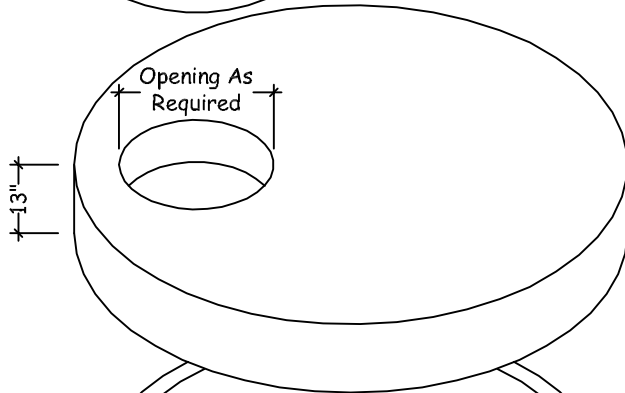
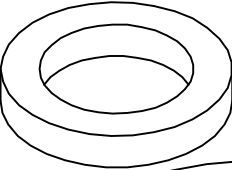

Opening As
 Required

13"

Riser Section
 1'-0" - 4'-0"
 6" Increments

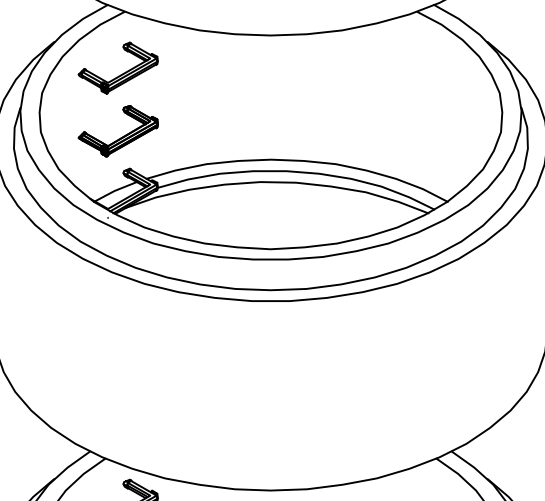

Base Section
 2'-0" - 5'-0"
 1'-0" Increments
 8" Base

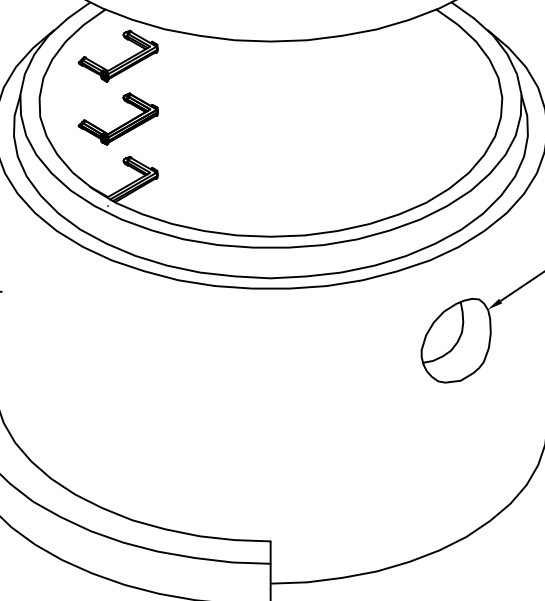

Extended Base
 Slab Optional

Isometric View

Design Criteria:

- Concrete: 4000 Psi @28 Days
- Entrained Air: 5% - 9%
- Design Loading: AASHTO H-25
- Reinforcement: BAR-ASTM A615 GR60
 WWR-ASTM A185

Specifications:

1. Joints Sealed With Butyl Sealant - ASTM C990
2. Monolithic Construction
3. Meets ASTM C478
4. Bitumastic Coating (If Required)
5. "O" Ring Gasket (If Required)

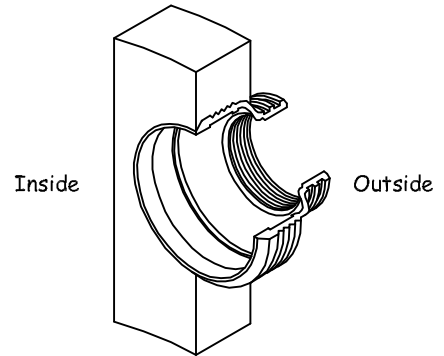

Kon-N-Seal Boots
 From NPC

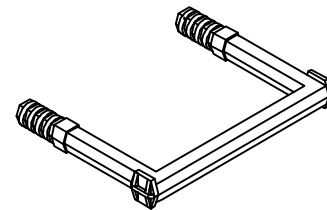

M.A. Industries
 Manhole Step
 PS-1PF

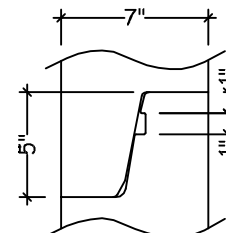

Joint Detail