

# NYS DOT 655-03 #9 Reticuline Grate & Frame

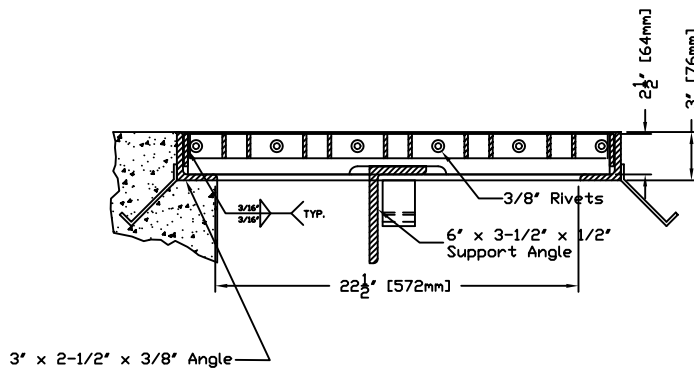
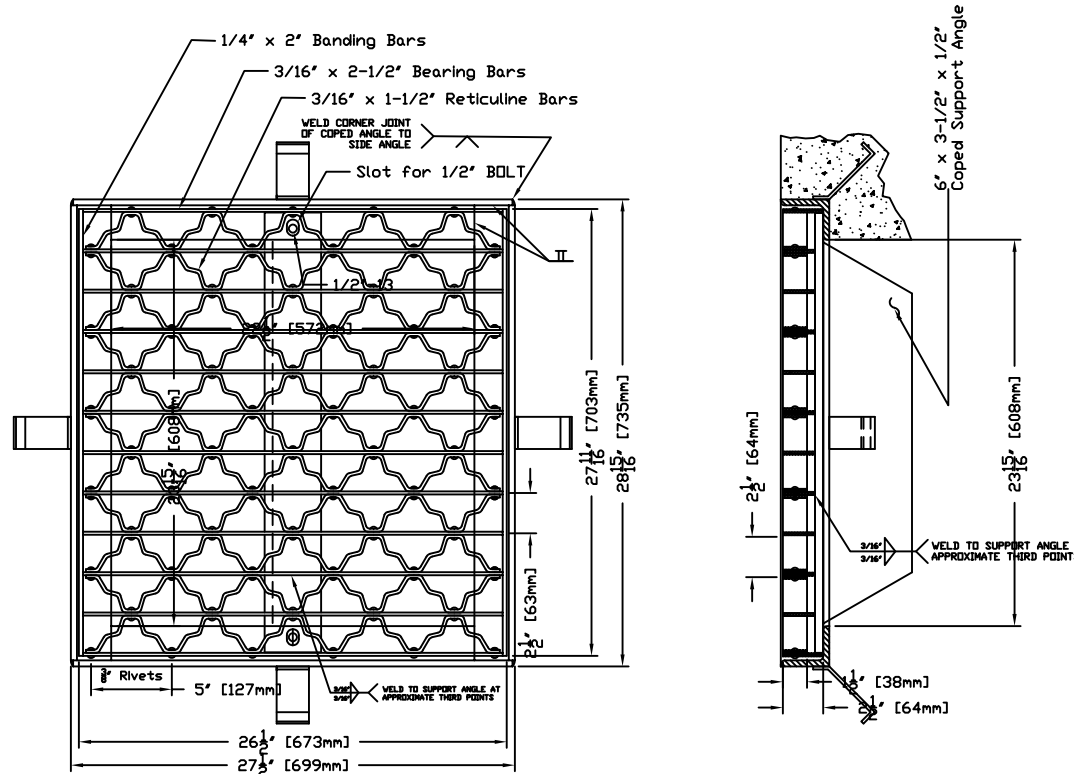

**FRAME NOTES:**  
 MATERIAL SHALL BE HOT ROLLED STEEL CONFORMING TO ASTM A36.  
 ALL STEEL SHALL BE MADE FROM DOMESTIC MILLS ONLY (MADE IN USA).  
 GRATE SHALL BE GALVANIZED IN CONFORMANCE WITH SUBSECTION 719-01 TYPE 1 OF THE NYS DOT STANDARD SPECIFICATIONS, ASTM A123 AFTER FABRICATION.

**GRATE NOTES:**  
 3/16" x 2-1/2" BEARING BARS SHALL BE HOT ROLLED STEEL CONFORMING TO ASTM A1011.  
 3/16" x 1-1/2" RETICULINE BARS SHALL BE HOT ROLLED STEEL CONFORMING TO ASTM A1011.  
 ALL OTHER MATERIAL SHALL BE HOT ROLLED STEEL CONFORMING TO ASTM A36.  
 ALL STEEL SHALL BE MADE FROM DOMESTIC MILLS ONLY (MADE IN USA).  
 GRATE SHALL BE GALVANIZED IN CONFORMANCE WITH SUBSECTION 719-01 TYPE 1 OF THE NYS DOT STANDARD SPECIFICATIONS, ASTM A123 AFTER FABRICATION.  
 EACH UNIT SHALL BE FABRICATED PER FORMER NYS DOT STANDARD SHEET 655-3 & CURRENT SHEET 655-04.

**Product Number**  
 655F-09WA4 & 65503G-09

**Design Features**  
 -Materials  
 Hot Rolled Steel  
 -Design Load  
 Per NYS DOT Standard Sheet  
 655-05 &  
 655-07  
 -Coating  
 Galvanized

**Certification**  
 WT 176 lbs  
 -Country of Origin: Made in USA

**Drawing Revision**  
 07/30/13 Designer: TJM  
 04/03/2014 Revised By: BDD

**Disclaimer**  
 Weights (lbs/kg), dimensions (inches/mm) and drawings provided for your guidance. We reserve the right to modify specifications without prior notice.

CONFIDENTIAL: This drawing is the property of EJ Group, Inc. and embodies confidential information, registered marks, patents, trade secret information, and/or know-how that is the property of EJ Group, Inc. Copyright © 2011 EJ Group, Inc. All rights reserved.

**Contact**  
 800 626 4653  
 ejco.com