



Lakelands Concrete Products, Inc.  
7520 East Main St., Lima, NY 14485  
Phone: 585-624-1990, Fax: 585-624-2102

Web: [www.lakelandsconcrete.com](http://www.lakelandsconcrete.com)  
E-mail: [sales@lakelandsconcrete.com](mailto:sales@lakelandsconcrete.com)

Date: 7/5/11

DWG: AGHS

## Hog Slats

AGHS

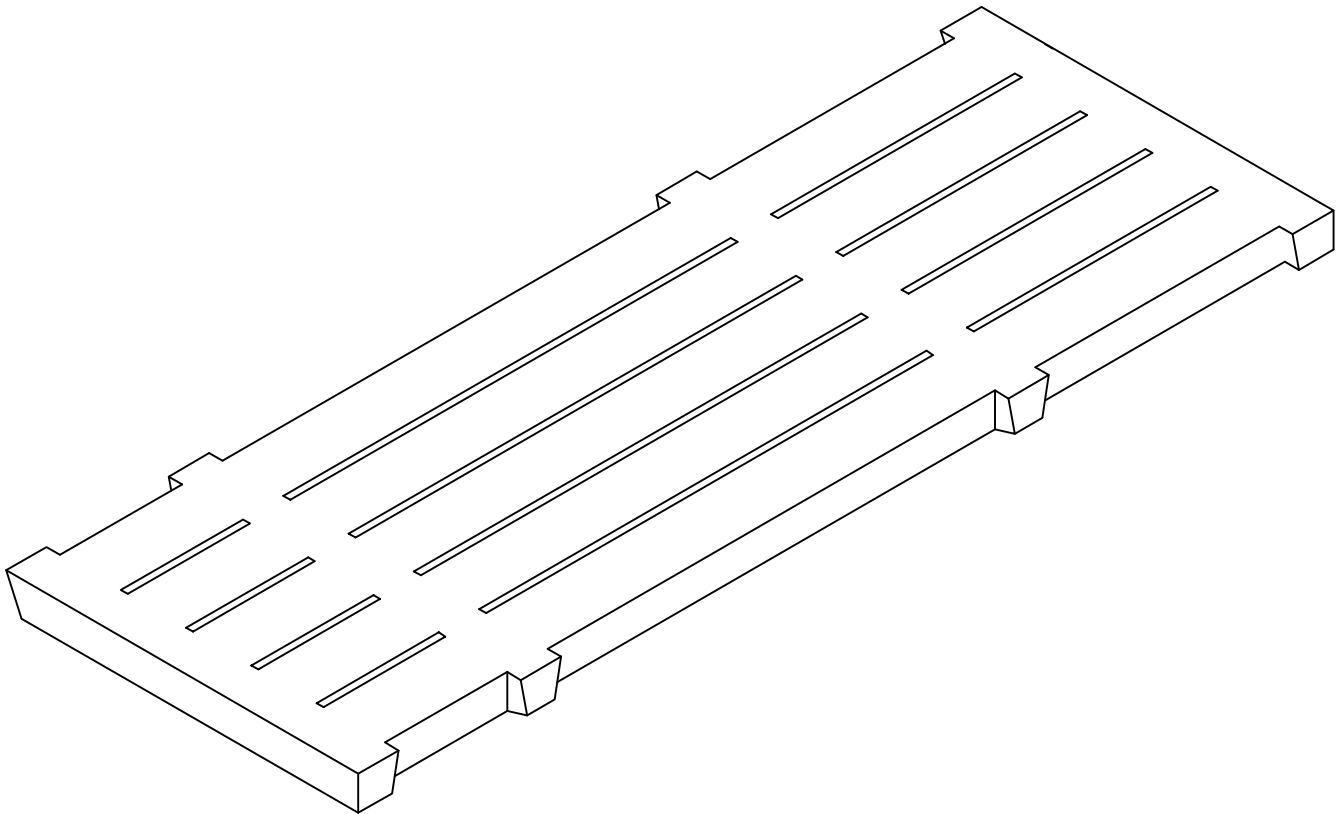



Lakelands Concrete Products, Inc.  
 7520 East Main St., Lima, NY 14485  
 Phone: 585-624-1990, Fax: 585-624-2102

Web: [www.lakelandsconcrete.com](http://www.lakelandsconcrete.com)  
 E-mail: [sales@lakelandsconcrete.com](mailto:sales@lakelandsconcrete.com)

Date: 7/5/11

DWG: AGHS

# Hog Slats

AGHS

**Specifications:**

Design Criteria: 5000 Psi @28 Days

Entrained Air: 5% - 9%

Reinforcement: BAR-ASTM A615 GR60  
 WWR-ASTM A185/A497 GR65

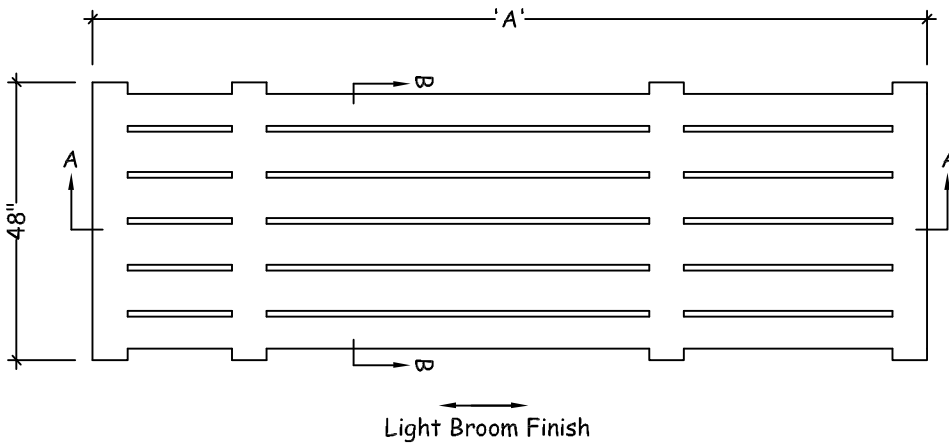

PLAN VIEW

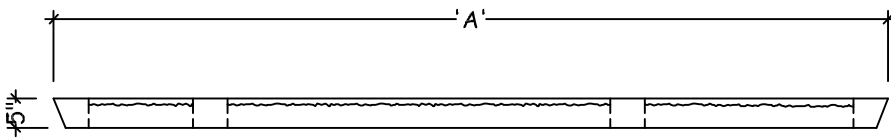

SECTION VIEW 'A'

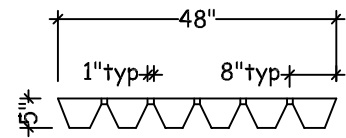

SECTION VIEW 'B'

Note:  
 \*175 lbs Per Lineal Foot

Model No.	A	Weight
AGHS-8	8'-0"	1400#
AGHS-10	10'-0"	1750#
AGHS-12	12'-0"	2100#