



Lakelands Concrete Products, Inc.  
7520 East Main St., Lima, NY 14485  
Phone: 585-624-1990, Fax: 585-624-2102

Web: [www.lakelandsconcrete.com](http://www.lakelandsconcrete.com)  
E-mail: [sales@lakelandsconcrete.com](mailto:sales@lakelandsconcrete.com)

Date: 12/13/10

DWG: AGJB

J - Bunks

AGJB

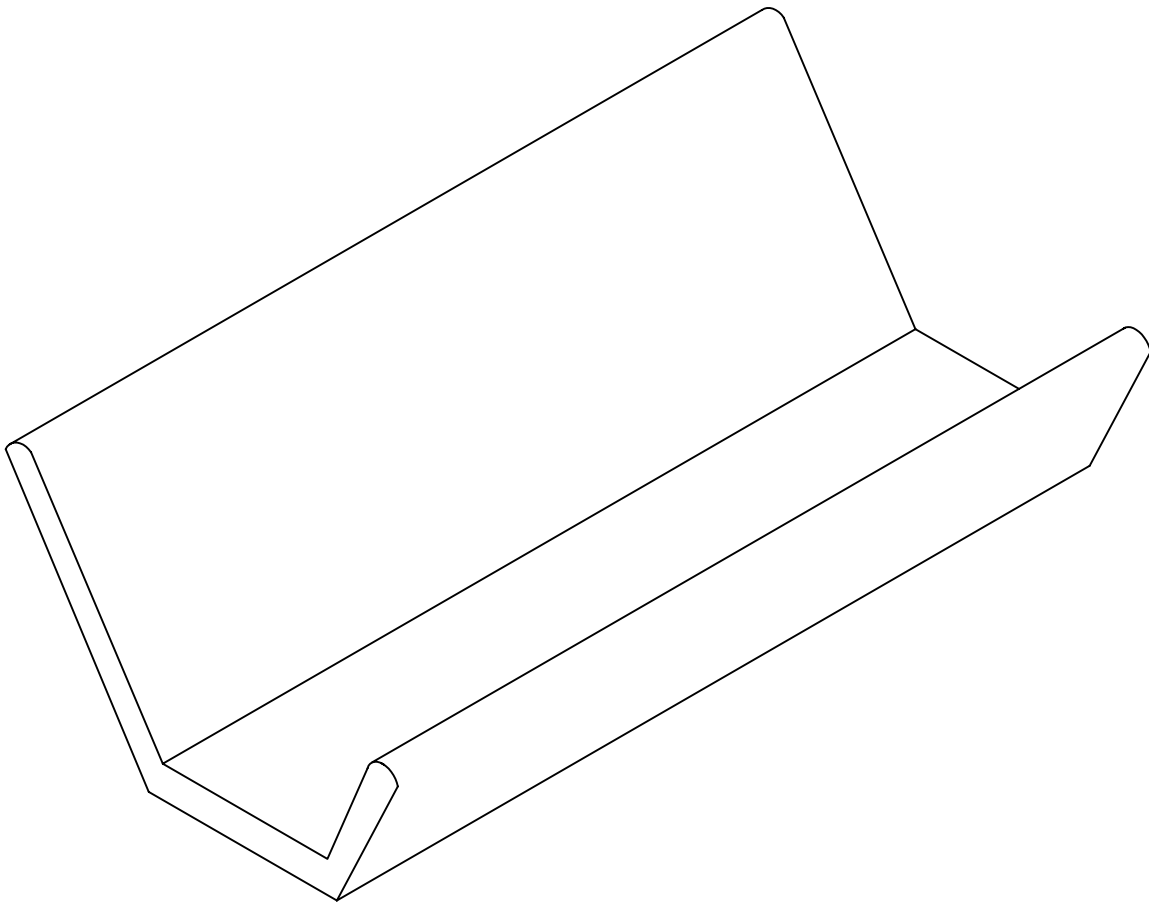



Lakelands Concrete Products, Inc.  
 7520 East Main St., Lima, NY 14485  
 Phone: 585-624-1990, Fax: 585-624-2102

Web: [www.lakelandsconcrete.com](http://www.lakelandsconcrete.com)  
 E-mail: [sales@lakelandsconcrete.com](mailto:sales@lakelandsconcrete.com)

Date: 12/13/10

DWG: AGJB

J - Bunks

AGJB

Specifications:

Design Criteria: 5000 Psi @28 Days

Entrained Air: 5% - 9%

Reinforcement: BAR-ASTM A615 GR60

WWR-ASTM A185/A497 GR65

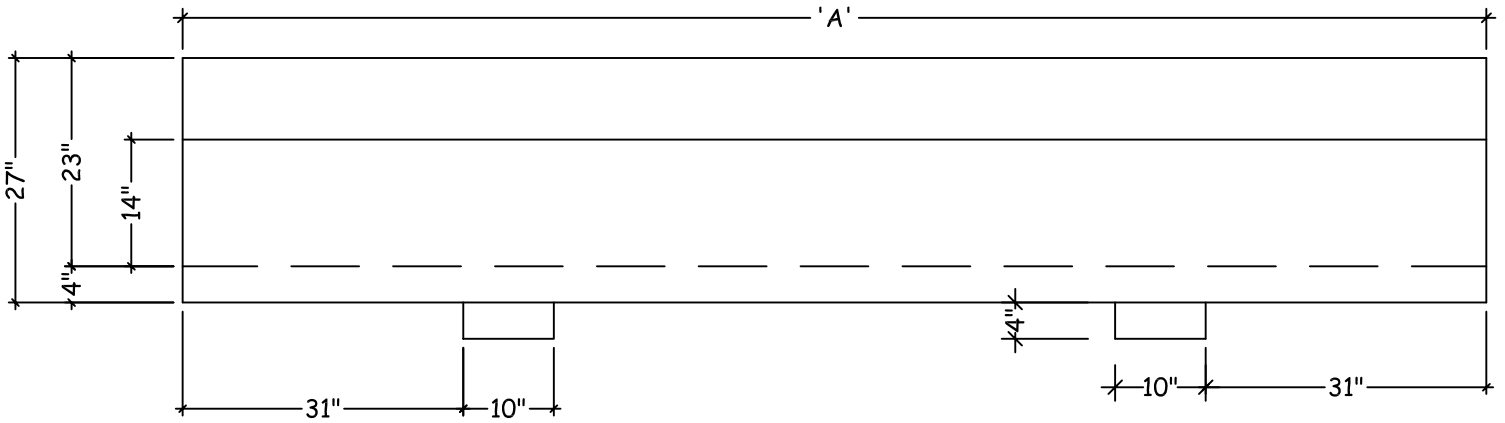

Elevation View

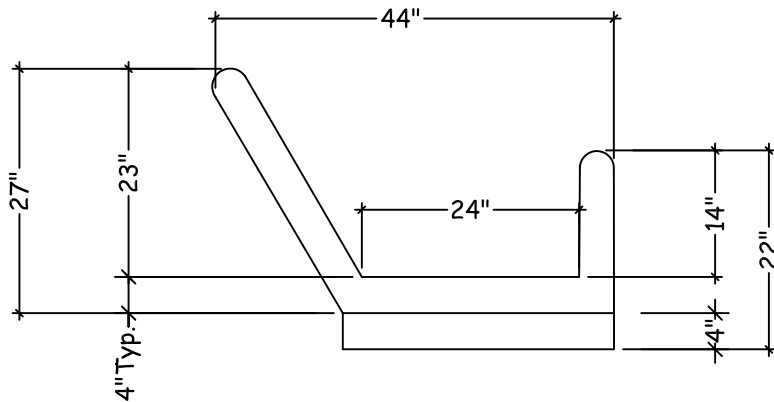

Plan View

Model No.	A	Weight
AGJB-8	8'-0"	2525 LBS
AGJB-10	10'-0"	2995 LBS
AGJB-12	12'-0"	3575 LBS