



Lakelands Concrete Products, Inc.  
7520 East Main St., Lima, NY 14485  
Phone: 585-624-1990, Fax: 585-624-2102

Web: [www.lakelandsconcrete.com](http://www.lakelandsconcrete.com)  
E-mail: [sales@lakelandsconcrete.com](mailto:sales@lakelandsconcrete.com)

Date: 12/16/10

DWG: BR-BC

### Precast Concrete Box Culvert

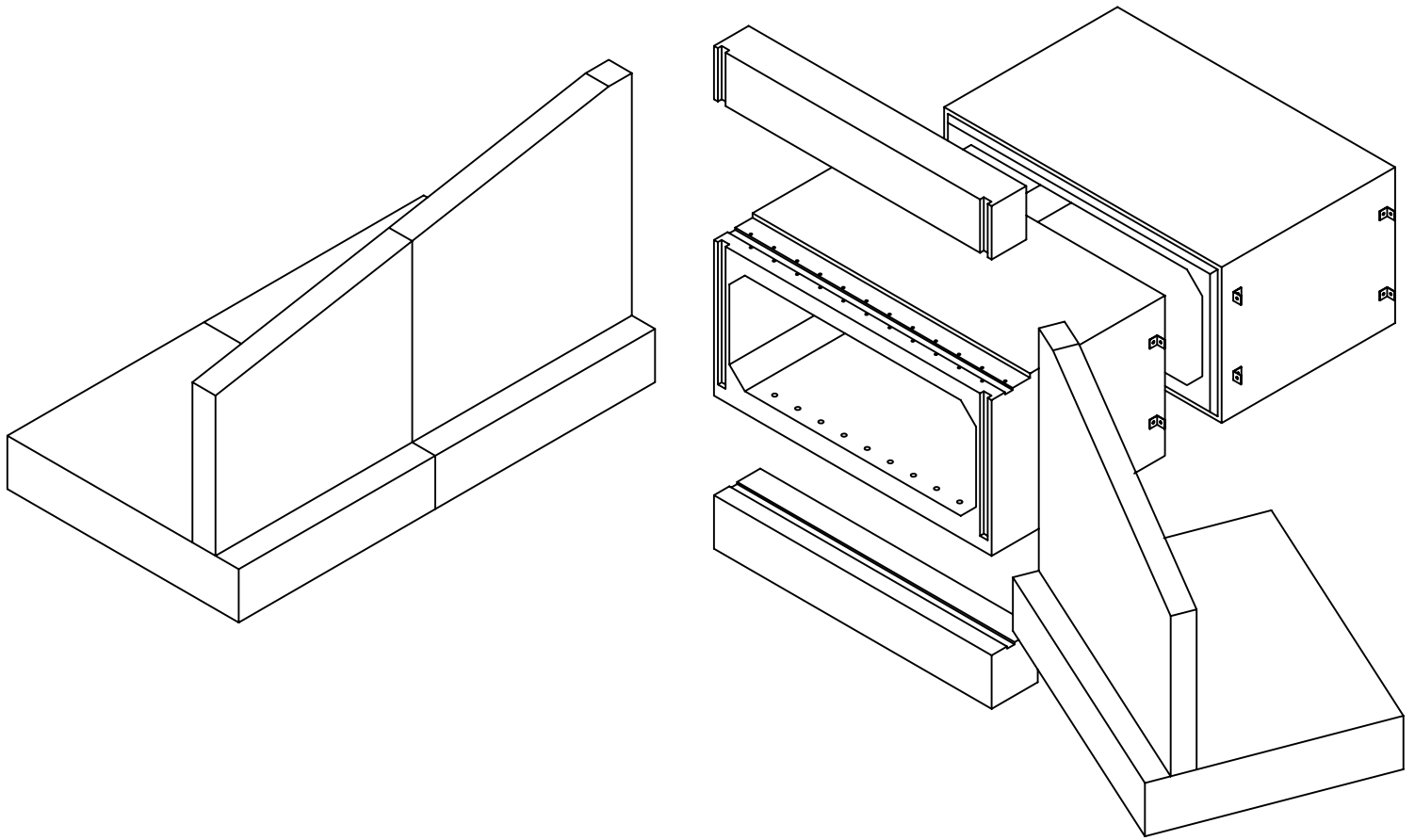



Lakelands Concrete Products, Inc.  
 7520 East Main St., Lima, NY 14485  
 Phone: 585-624-1990, Fax: 585-624-2102

Web: [www.lakelandsconcrete.com](http://www.lakelandsconcrete.com)  
 E-mail: [sales@lakelandsconcrete.com](mailto:sales@lakelandsconcrete.com)

Date: 12/16/10

DWG: BR-BC

Precast Concrete  
 Box Culvert

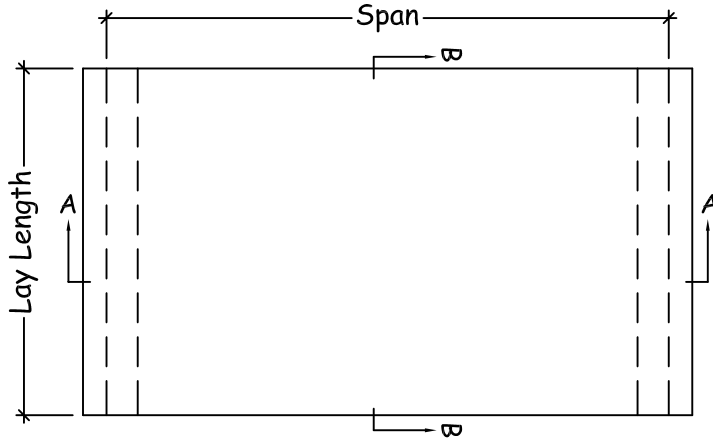

PLAN VIEW

Specifications:

Design Criteria: 5000 Psi @28 Days

Entrained Air: 5% - 9%

Design Loading: AASHTO HS20, HS25

Reinforcement: BAR-ASTM A615 GR60

WWR-ASTM A185/A497 GR65

Notes:

\*Tapered And Skewed End Sections Available

\*Maximum Lay Length Per Section = 7'-6"

\*Ship Lap Joints

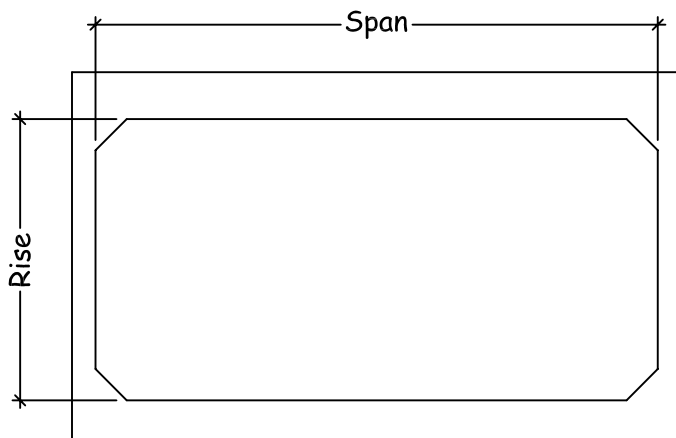

SECTION VIEW 'A'

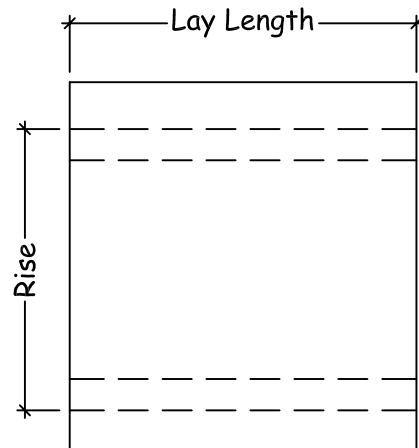

SECTION VIEW 'B'

Weights:  
 60,000 LBS Max.  
 Per Section