



7520 EAST MAIN STREET, LIMA NY 14485
 PH: 585-624-1990 - FAX: 585-624-2102
 WEB: WWW.LAKELANDSCONCRETE.COM
 E-MAIL: SALES@LAKELANDSCONCRETE.COM

DATE: 10/16/2020 DWG: CB484836

CATCH BASIN
 4'-0" x 4'-0" x 3'-0"

DESIGN CRITERIA:

CONCRETE: 5000 PSI @ 28 DAYS
 ENTRAINED AIR: 5% - 9%
 DESIGN LOADING: AASHTO HS20-44 WITH LESS THAN
 2'-0" EARTH COVER
 REINFORCEMENT: BAR-ASTM A615 GR60
 WWR-ASTM A185

SPECIFICATIONS:

1. CUSTOM KNOCKOUTS OR OPENINGS ARE AVAILABLE UPON REQUEST
2. FIELD/FRAME ADJUSTMENT SIZED PER CUSTOMERS REQUEST
3. BITUMASTIC COATING AVAILABLE IF REQUIRED
4. BOOTS/LINK SEALS PROVIDED IF REQUIRED (LAKELANDS MUST BE NOTIFIED)
5. SUMPS AS NEEDED BY CUSTOMERS REQUEST
6. CUSTOMER TO GROUT ANY KEYWAYS AS REQUIRED
7. CUSTOMER IS RESPONSIBLE OF THE FRAME INSTALLATION IN FIELD (IF REQUIRED)

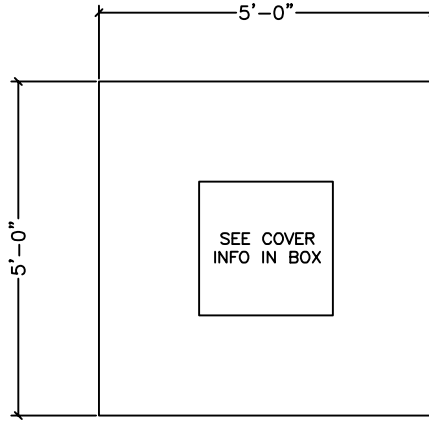

PLAN VIEW
 OPTIONAL COVER ONLY

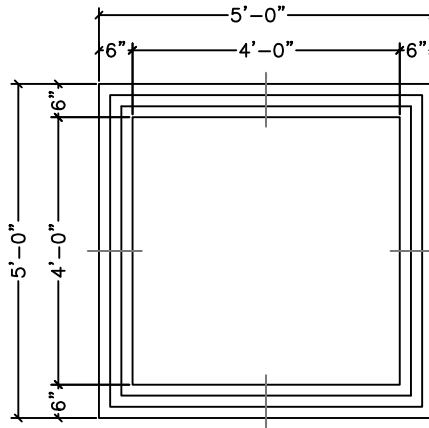

PLAN VIEW
 OPTIONAL COVER REMOVED

COVER
 OPENING SIZE: _____
 NOT NEEDED

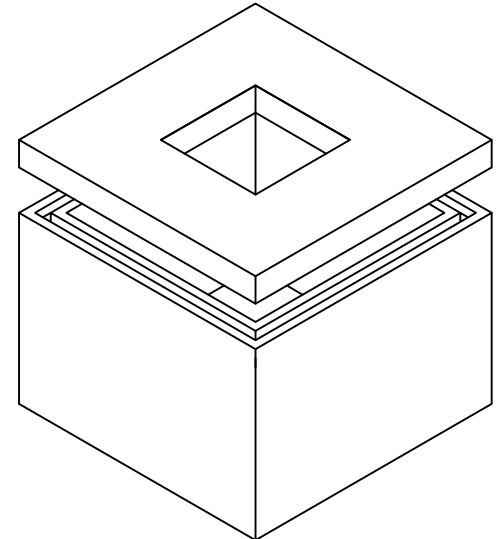

ISOMETRIC VIEW

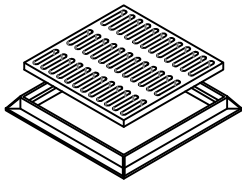

FRAME & GRATE

FRAME & GRATE
 MODEL NO: _____
 NOT NEEDED

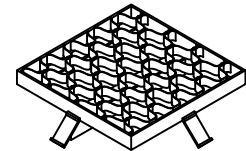

CAST-IN COLLAR FRAME AND GRATE

CAST-IN FRAME & GRATE
 MODEL NO: _____
 NOT NEEDED

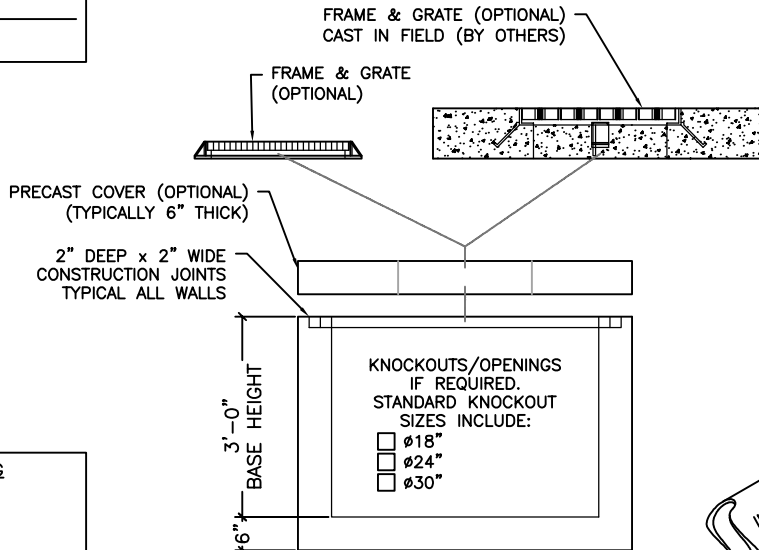

ELEVATION VIEW

BITUMASTIC COATING

EXTERIOR
 INTERIOR
 EXTERIOR AND INTERIOR
 NOT NEEDED

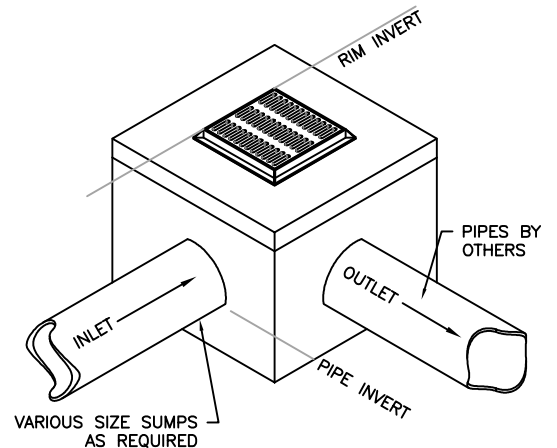

IN-FIELD VIEW

COMPONENT	SIZE	WEIGHT (LBS)
OPTIONAL COVER	STANDARD 24"x24" OPENING	1580
CATCH BASIN	36"	5925