



7520 EAST MAIN STREET, LIMA NY 14485
 PH: 585-624-1990 - FAX: 585-624-2102
 WEB: WWW.LAKELANDSCONCRETE.COM
 E-MAIL: SALES@LAKELANDSCONCRETE.COM

DATE: 1/5/2021

DWG: AGHB-8

AGRICULTURAL
 H-BUNK
 5'-0" x 8'-0"

DESIGN CRITERIA:

CONCRETE: 5000 PSI @ 28 DAYS

ENTRAINED AIR: 5% - 9%

REINFORCEMENT: BAR-ASTM A615 GR60

WWR-ASTM A185/A497 GR65

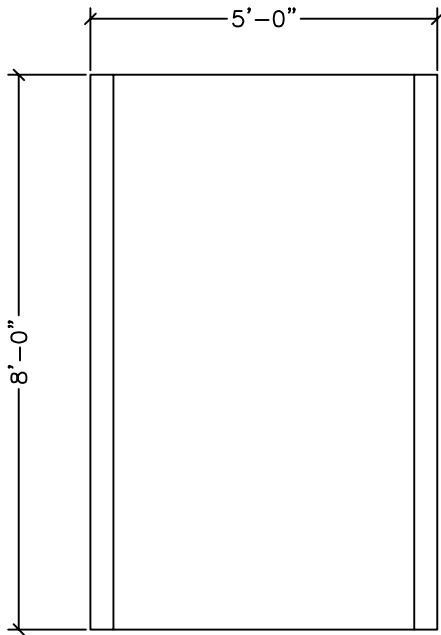

PLAN VIEW

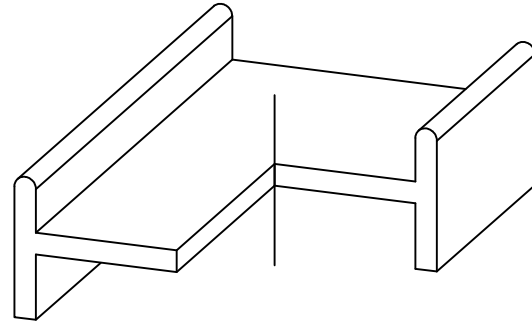

ISOMETRIC VIEW

COMPONENT	WEIGHT (LBS)
H-BUNK	3440

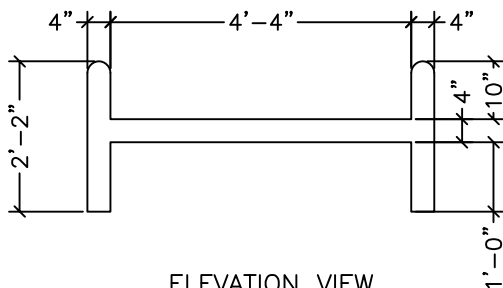

ELEVATION VIEW