



7520 EAST MAIN STREET, LIMA NY 14485
 PH: 585-624-1990 - FAX: 585-624-2102
 WEB: WWW.LAKELANDSCONCRETE.COM
 E-MAIL: SALES@LAKELANDSCONCRETE.COM

DATE: 1/5/2021

DWG: AGS-BLOCK

AGRICULTURAL
 S-BLOCK
 2'-0" x 1'-0" x 0'-4"

DESIGN CRITERIA:

CONCRETE: 5000 PSI @ 28 DAYS

ENTRAINED AIR: 5% - 9%

REINFORCEMENT: BAR-ASTM A615 GR60

WWR-ASTM A185/A497 GR65

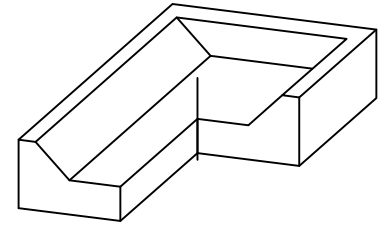

ISOMETRIC VIEW

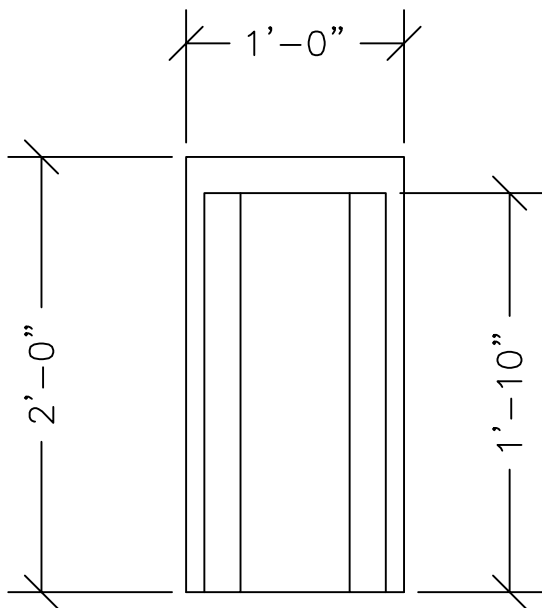

PLAN VIEW

COMPONENT	WEIGHT (LBS)
S-BLOCK	100

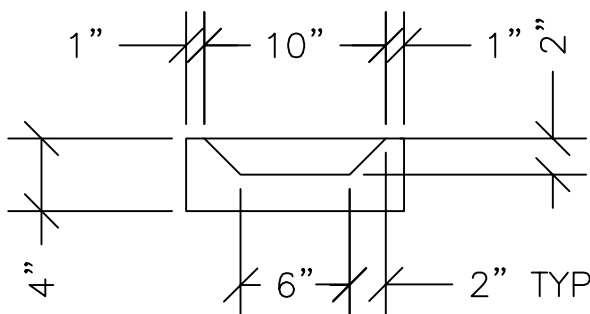

ELEVATION VIEW